

## Engine Front Cover

### Special Tool(s)

 <p>ST2439-A</p>	Aligner, Front Cover 303-093 (T74P-6019-A)
---	---

### Material

Item	Specification
Motorcraft® Metal Surface Prep ZC-31-A	—
Motorcraft® SAE 5W-30 Premium Synthetic Blend Motor Oil XO-5W30-QSP (US); Motorcraft® SAE 5W-30 Super Premium Motor Oil CXO-5W30-LSP12 (Canada); or equivalent	WSS-M2C929-A
Silicone Gasket and Sealant TA-30	WSE-M4G323-A4
Motorcraft® Silicone Gasket Remover  ZC-30	—
Thread Sealant with PTFE TA-24	WSK-M2G350-A2

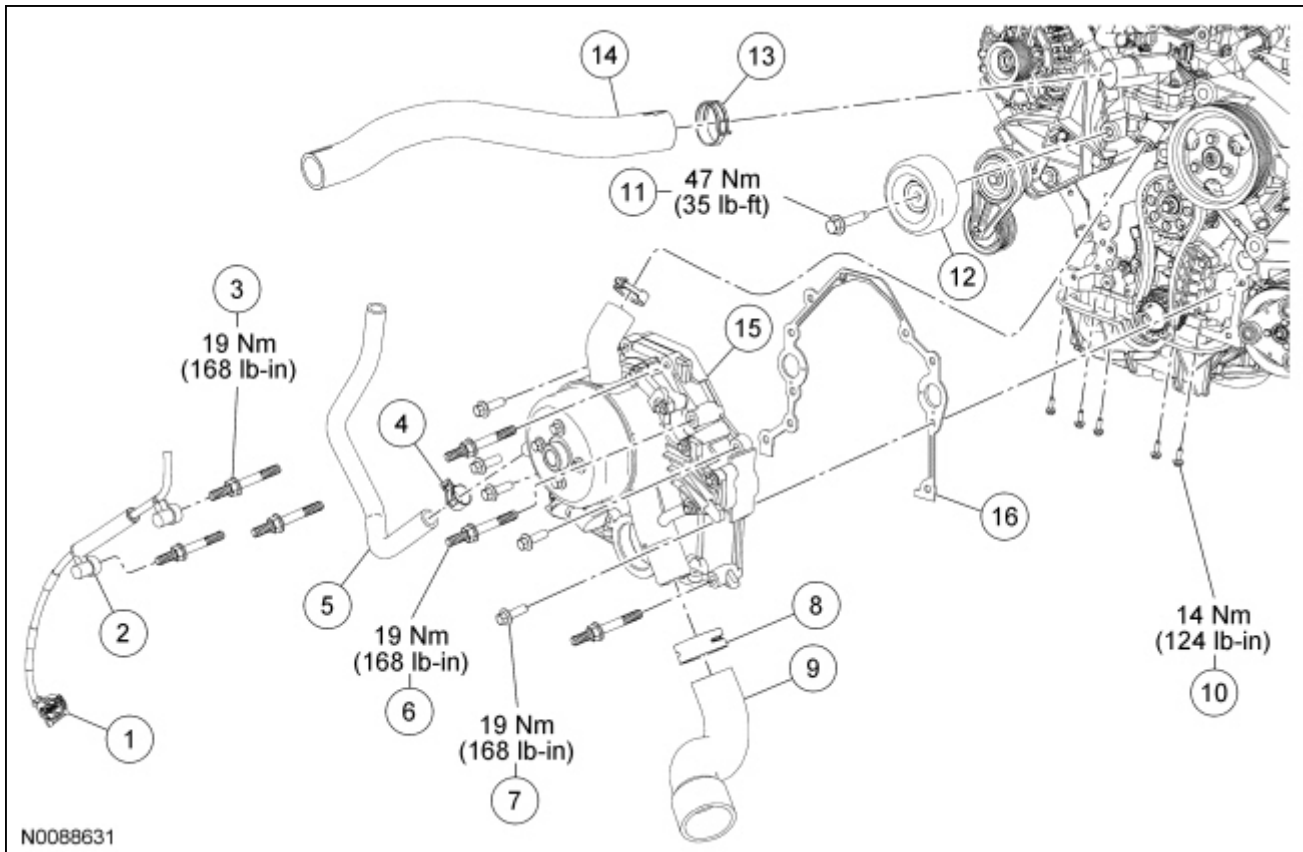

N0088631

Item	Part Number	Description
1	14A464	Crankshaft Position (CKP) sensor electrical connector (part of 12B637)
2	—	Wiring retainer (part of 12B637)
3	W702501	Engine front cover stud bolt (4 required)
4	8287	Clamp
5	18C266	Coolant hose
6	W702501	Engine front cover stud bolt
7	W500024	Engine front cover bolt (5 required)
8	15161	Clamp
9	8286	Lower radiator hose
10	E802185	Block cradle-to-engine front cover bolt (5 required)
11	—	Accessory drive belt idler pulley bolt (part of 6C348)
12	6C348	Accessory drive belt idler pulley
13	15161	Clamp
14	8620	Upper radiator hose
15	6019	Engine front cover
16	—	Engine front cover gasket

## Removal

**NOTICE:** During engine repair procedures, cleanliness is extremely important. Any foreign material, including any material created while cleaning gasket surfaces that enters the oil passages, coolant passages or the oil pan, can cause engine failure.

1. Drain the cooling system. For additional information, refer to [Section 303-03A](#).

2. Remove the crankshaft front oil seal. For additional information, refer to [Crankshaft Front Seal](#) in this section.
3. Disconnect the upper radiator hose.
4. Disconnect the heater hose from the coolant pump.
5. Disconnect the lower radiator hose from the coolant pump.
6. Remove the bolt and the accessory drive belt idler pulley.
7. Disconnect the Crankshaft Position (CKP) sensor and detach the 2 wiring retainers.
8. Remove the 5 engine block cradle-to-engine front cover bolts.
9. Remove the 5 bolts and the 5 stud bolts from the engine front cover.
10. Disconnect the coolant bypass hose from the coolant pump and remove the engine front cover.
11. **NOTE:** Make sure that any coolant that drains into the front corners of the engine block cradle is removed.

Remove the oil pan drain plug and drain the engine oil.

- Install the drain plug and tighten to 26 Nm (19 lb-ft).

## Installation

1. **NOTICE:** Do not use metal scrapers, wire brushes, power abrasive discs or other abrasive means to clean sealing surfaces. These tools cause scratches and gouges which make leak paths.

Clean and inspect the gasket mating surfaces. Use silicone gasket remover and metal surface prep and a plastic or wooden scraping tool. Follow the directions on the packaging.

2. Position a new front cover gasket.

**NOTICE:** If not secured within 4 minutes, the sealant must be removed and the sealing area cleaned. To clean the sealing area, use silicone gasket remover and metal surface prep. Follow the directions on the packaging. Failure to follow this procedure can cause future oil leakage.

3. Apply silicone gasket and sealant to the oil pan and engine block mating surfaces.

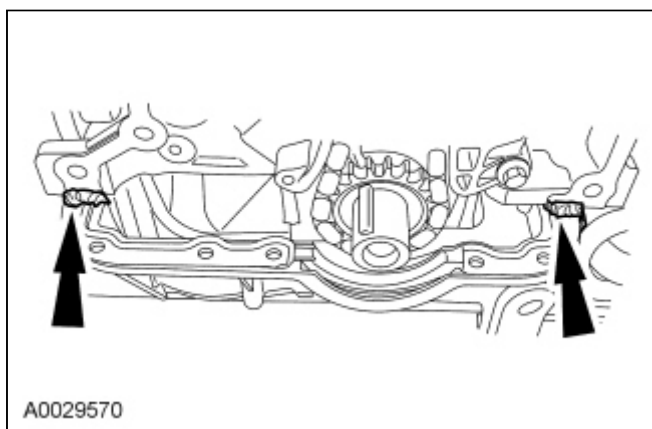

4. Apply silicone gasket and sealant to the front cover in 2 places.

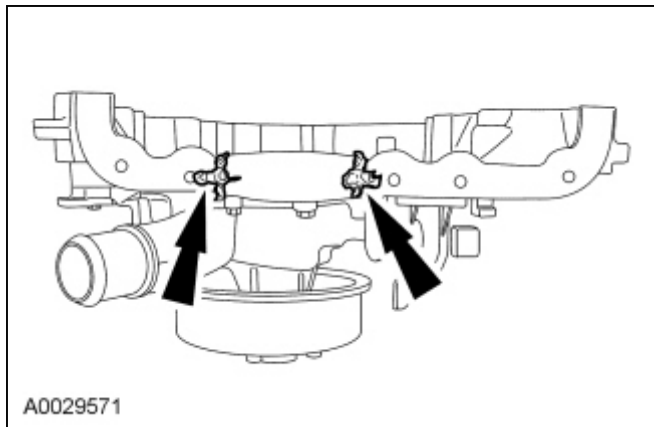

5. **NOTE:** Apply thread sealant to the stud bolts and make sure that the stud bolts are installed in their original positions.

Position the front cover and connect the coolant bypass hose to the thermostat housing.

- Loosely install the 5 bolts and the 5 stud bolts.

6. Use the Front Cover Aligner, align the front cover.
  - Tighten the bolts and stud bolts to 19 Nm (168 lb-in).

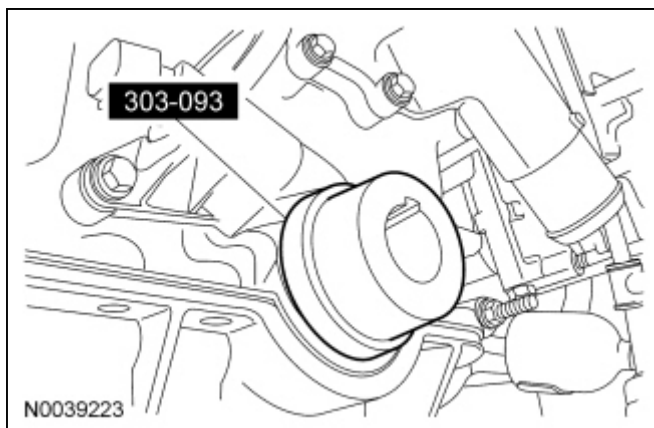

7. Install the 5 engine block cradle-to-engine front cover bolts.
  - Tighten to 14 Nm (124 lb-in).
8. Connect the [CKP](#) sensor and attach the 2 wiring retainers.
9. Install the accessory drive belt idler pulley and the bolt.
  - Tighten to 47 Nm (35 lb-ft).
10. Connect the lower radiator hose to the coolant pump.
11. Connect the heater hose to the coolant pump.
12. Connect the upper radiator hose.
13. Install the crankshaft front oil seal. For additional information, refer to [Crankshaft Front Seal](#) in this section.
14. Fill the engine with clean engine oil.
15. Fill and bleed the engine cooling system. For additional information, refer to [Section 303-03A](#).

